

## THE OC400HC CONSOLE TENDER

The Beast in Tuxedo. Our largest and most complete tender pulling all the stops without compromising the ethos that simplicity and efficiency comes hand in hand with practicality and results. Maximum space in tender size. Ideal for 6 plus pax. Weight include phifer rubrail and full alloy delta.

Overall length (m/ft)	3.91m	12.83ft
Overall width (m/ft)	1.72m	5.64ft
Bow top side height	0.79m	2.59ft
Stern top side height	0.61m	2ft
Carbon hull weight incl. phifer rubrail and full alloy delta	78kg	187lb
Recommended max hp	Short Shaft	20hp
Max load	533kg	1175lb

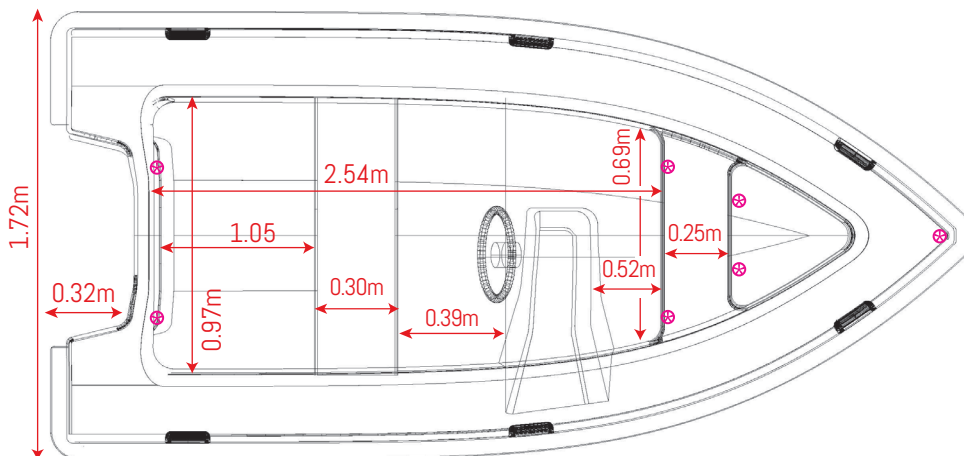
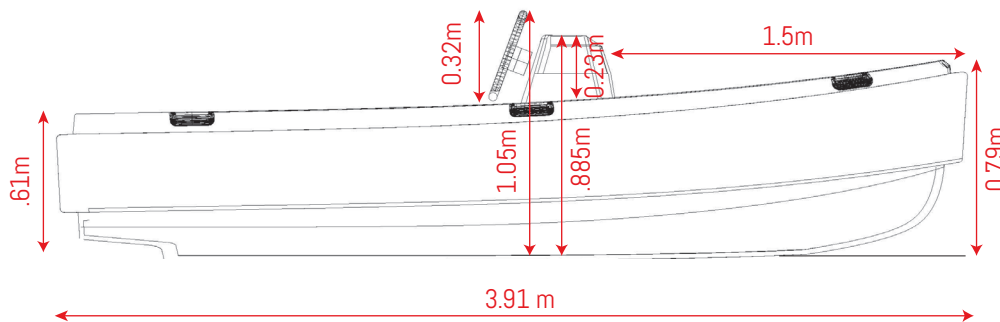

⊗ Davit lifting points

### MODEL INCLUDES

- Tender
- Side arm console
- Cushion bench seat
- Phifer rub rail cover black/grey/beige
- Full non skid on deck & cockpit floor
- 1.2mm Alloy Delta Panel
- Delta point drop plate
- Oarlocks & Oars
- Anchor bag
- Mesh tank bulkhead
- Two side storage bags
- Two seat block
- Large draining bung
- Davit lifting eyes (3 sets)
- Floating painter
- Bow guard

### ACCESSORIES

- Full Carbon construction
- Custom colour Rub Rail cover
- Two Folding & removable seat
- Full boat cover
- Telescopic ladder (3 steps)
- Vinyl Name cutting ("Tender to S.V. ...")
- Fishing Rod Holders (sold in pairs)
- Anchor pack
- Wheels (retractable)
- Folding Bimini (starport installed)
- Board rack
- Bow lid
- Custom lifting points



+64 9 974 6745  
 info@octenders.com  
 facebook.com/octenders  
 instagram.com/octenders  
 octenders.com

PO Box 101  
 Paihia, 0200  
 Bay of Islands  
 New Zealand