

OC350HC CONSOLE TENDER

The Big Mamma tender with creature comforts. Recommended for 5 people. State specs are for tender with full non skid, deck and hull, rubstreak, standard alloy protection, side arm console, steering wheel & cables, bench seat and cushion. Pair of seats on brackets optional.

Overall length (m/ft)	3.5m	11.5ft
Overall width (m/ft)	1.60m	5.24ft
Glass Tender weight	64kg	156lb
Carbon Tender weight	54kg	134lb
Recommended max hp	Short Shaft	Max 20hp
Max load	455kg	1003lb

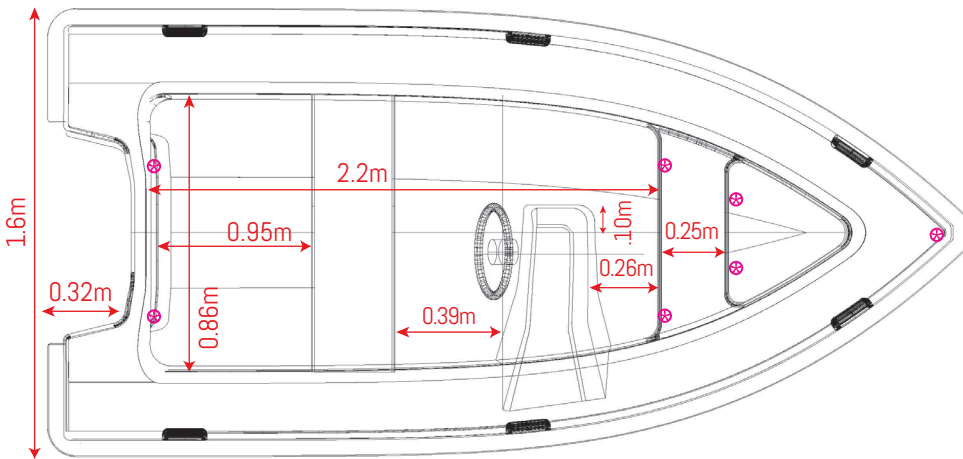
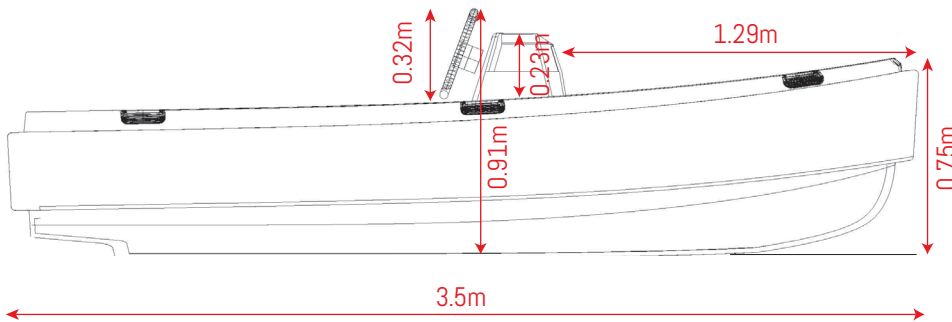

⊗ Davit lifting points

MODEL INCLUDES

Tender
Side arm console
Cushion bench seat
Black rub rail cover
Full non skid on deck & cockpit floor
40cm X 40cm stern drag plate
Delta point drop plate
Oarlocks & Oars
Anchor bag
Mesh tank bulkhead
Two side storage bags
One seat block
Large draining bung
Davit lifting eyes (3 sets)
Floating painter
Bow guard

ACCESSORIES

Full Carbon construction
Custom colour Rub Rail cover
Phifer rub rail cover
Full boat cover
1.2mm Alloy Delta Panel – 4kg
Vinyl Name cutting ("Tender to S.V. ...")
Fishing Rod Holders (sold in pairs)
Telescopic ladder (3 steps)
Wheels (retractable)
Folding Bimini (starport installed)
Board rack
Anchor pack
Bow lid
Custom lifting points
Extra drain plug
Two Folding & removable seat (7Kg)



+64 9 974 6745
 info@octenders.com
 facebook.com/octenders
 instagram.com/octenders
 octenders.com

PO Box 101
 Paihia, 0200
 Bay of Islands
 New Zealand