

OC330HC CONSOLE TENDER

Our most popular offshore cruising size now with a console. Recommended for 4 pax. Stated specs are for a standard tender with full non skid deck and hull, rubstreak, standard alloy protection, side arm console, steering wheel & cables, bench seat and cushion. Pair of seats on brackets optional.

Overall length (m/ft)	3.3m	10.8ft
Overall width (m/ft)	1.60m	5.24ft
Glass Tender weight	58kg	143lb
Carbon Tender weight	49kg	123lb
Recommended max hp	Short Shaft	Max. 20hp
Max load	377kg	832lb

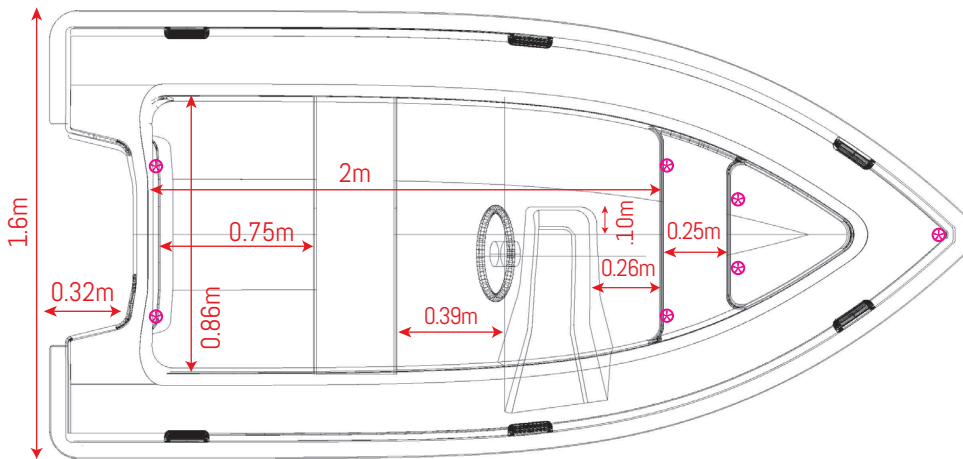
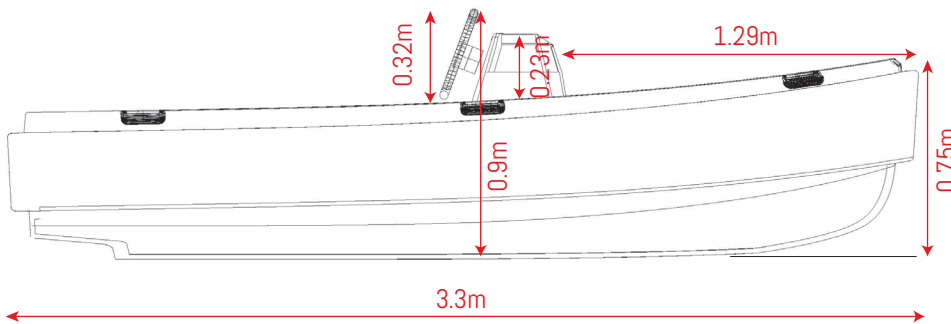

⊗ Davit lifting points

MODEL INCLUDES

- Tender
- Side arm console
- Cushion bench seat
- Black rub rail cover
- Full non skid on deck & cockpit floor
- 40cm X 40cm stern drag plate
- Delta point drop plate
- Oarlocks & Oars
- Anchor bag
- Mesh tank bulkhead
- Two side storage bags
- One seat block
- Large draining bung
- Davit lifting eyes (3 sets)
- Floating painter
- Bow guard

ACCESSORIES

- Full Carbon construction
- Custom colour Rub Rail cover
- Phifer rub rail cover
- Full boat cover
- 1.2mm Alloy Delta Panel – 2.5kg
- Vinyl Name cutting ("Tender to S.V. ...")
- Fishing Rod Holders (sold in pairs)
- Telescopic ladder (3 steps)
- Wheels (retractable)
- Folding Bimini (starport installed)
- Board rack
- Anchor pack
- Bow lid
- Custom lifting points
- Extra drain plug
- Two Folding & removable seat (7kg)



+64 9 974 6745
 info@octenders.com
 facebook.com/octenders
 instagram.com/octenders
 octenders.com

PO Box 101
 Paihia, 0200
 Bay of Islands
 New Zealand