

SPECIFICATIONS

THE OC350 TENDER

The ultimate explorer tender. Go the distance, carry your toys, and all your crew to where you need to be.

Overall length (m/ft)	3.5m	11.48ft
Overall width (m/ft)	1.60m	5.24ft
Nett boat weight	54kg	119lb
Nett carbon boat weight	44kg	97lb
Recommended max hp	Short Shaft	Max. 20 hp
Max load	448kg	988lb

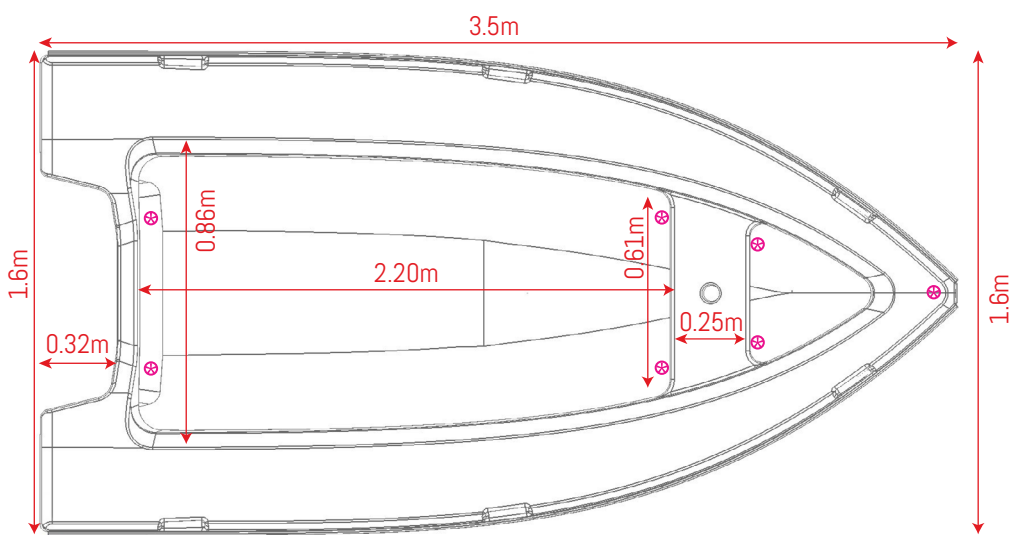
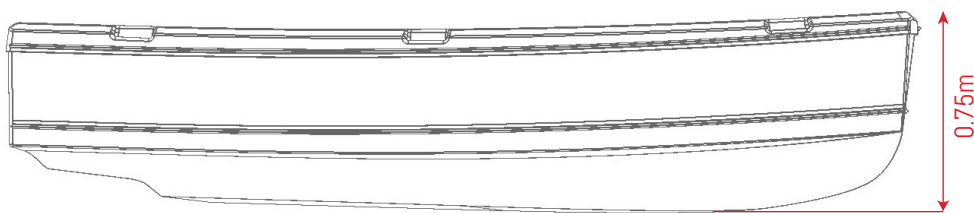

⊗ Davit lifting points

MODEL INCLUDES

Tender
Black rub rail cover
Full non skid on deck & cockpit floor
40cm X 40cm stern drag plate
Delta point drop plate
Oarlocks & Oars
Anchor bag
Mesh tank bulkhead
Two side storage bags
Two seat blocks
Large draining bung
Davit lifting eyes (3 sets)
Floating painter
Tiller extension
Bow guard

ACCESSORIES

Full Carbon construction
Custom colour Rub Rail cover
Phifer rub rail cover
Full boat cover
1.2mm Alloy Delta Panel – 2.5kg
Vinyl Name cutting ("Tender to S.V. ...")
Fishing Rod Holders (sold in pairs)
Telescopic ladder (3 steps)
Wheels (retractable)
Navigation lights (Railblaza NaviPack)
Board rack
Anchor pack
Bow lid
Custom lifting points
Extra drain plug



+64 9 974 6745
 info@octenders.com
 facebook.com/octenders
 instagram.com/octenders
 octenders.com

PO Box 101
 Paihia, 0200
 Bay of Islands
 New Zealand