

## SPECIFICATIONS

### THE OC330 TENDER

Have all the advantages of an OC350 with an OC330 fit.  
Great performance and volume for exploring in a more compact size.  
Great for a crew of 4 full time cruising.

Overall length (m/ft)	3.3m	10.82ft
Overall width (m/ft)	1.60m	5.24ft
Nett boat weight	48kg	105lb
Nett carbon boat weight	39kg	86lb
Recommended max hp	Short Shaft	Max. 20 hp
Max load	373kg	822lb

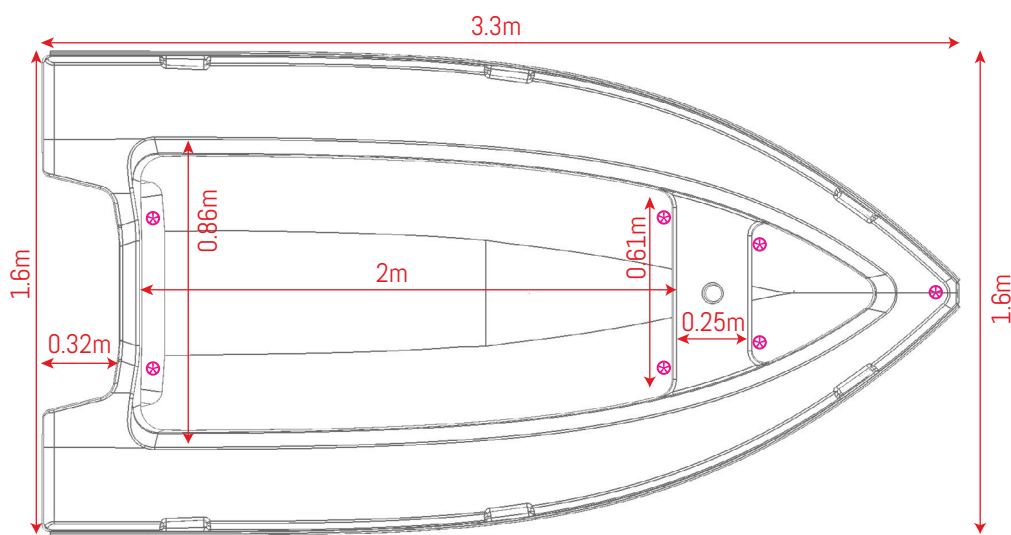
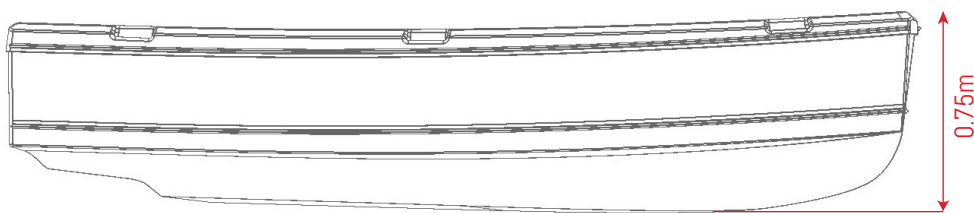

⊗ Davit lifting points

### MODEL INCLUDES

Tender
Black rub rail cover
Full non skid on deck & cockpit floor
40cm X 40cm stern drag plate
Delta point drop plate
Oarlocks & Oars
Anchor bag
Mesh tank bulkhead
Two side storage bags
Two seat blocks
Large draining bung
Davit lifting eyes (3 sets)
Floating painter
Tiller extension
Bow guard

### ACCESSORIES

Full Carbon construction
Custom colour Rub Rail cover
Phifer rub rail cover
Full boat cover
1.2mm Alloy Delta Panel – 2.5kg
Vinyl Name cutting ("Tender to S.V. ...")
Fishing Rod Holders (sold in pairs)
Telescopic ladder (3 steps)
Wheels (retractable)
Navigation lights (Railblaza NaviPack)
Board rack
Anchor pack
Bow lid
Custom lifting points
Extra drain plug



+64 9 974 6745  
[info@octenders.com](mailto:info@octenders.com)  
[facebook.com/octenders](https://facebook.com/octenders)  
[instagram.com/octenders](https://instagram.com/octenders)  
[octenders.com](https://octenders.com)

PO Box 101  
 Paihia, 0200  
 Bay of Islands  
 New Zealand